

Sormat ITH-Wi

Vinylester based winter resin, styrene free



ITH 300 Wi



ITH 410 Wi

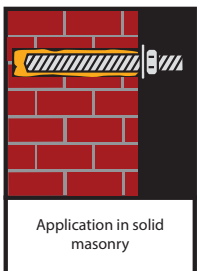
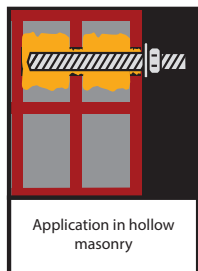
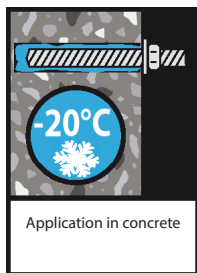

Content Page

Product description	2
Properties and benefits	2
Handling and storage	2
Applications and intended use	3
Curing times	3
Application in concrete	4
Installation instructions	4
Cleaning	6
Installation parameters	7
Capacities	8
Recommended loads	14
Application in masonry	16
Installation instructions	16
Cleaning	17
Load values	18
Chemical resistance	20

Sormat Oy
 Harjutie 5
 FIN-21290 Rusko, Finland
 Telephone +358 (0) 207 940 200
 Fax +358 (0) 201 76 3888
 www.sormat.com
 sormat@sormat.com

Sormat ITH-Wi

Vinylester based winter resin, styrene free

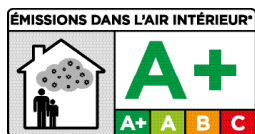

Product description

The ITH-Wi mortar is a 2-component reaction resin mortar based on a vinylester resin styrene free and will be delivered in a foil tube (72947; 300 ml) and coaxial cartridge system (72911; 410 ml). This high performance product may be used in combination with a hand-, battery-, or pneumatic tool and a static mixer. It was designed especially for the anchoring of threaded rods, reinforcing bars or internal threaded rod sleeves into concrete (also porous and light) as well as masonry with extremely low temperatures (as low as -20 °C). Based on the excellent standing behaviour the usability in combination with a plastic sleeve in hollow material is given. The ITH-Wi mortar is characterised, by a huge range of applications with an installation temperature from -20 °C and a service temperature up to 120 °C as well as by high chemical resistance for applications in extreme ambiances e.g. in swimming pools (chlorine) or in closeness to the sea (salt).

Properties and benefits

- Application until -20 °C ambient temperature and mortar temperature possible (the ease of installation can be improved by keeping mortar temperature above the minimum requirement)
- European technical approval acc. to ETAG 001-5 in concrete Opt 1+7: ETA-13/0774
Option 1 = threaded rod M12 - M30 / rebar Ø 12 - 32
Option 7 = threaded rod M8 + M10 / rebar Ø 8 + 10
Including also seismic anchor performance category (C1)
- Included into Sormat Trustfix calculation software (visit www.sormat.com to see more)
- For heavy anchoring - doweling and post-installed rebar connection
- Overhead application; water-filled bore holes
- Suitable for attachment points with small edge- and axial distances due to an anchoring free of expansion forces
- High chemical resistance
- Low odour and VOC content (A+), LEED tested
- High bending- and pressure strength
- Cartridge can be reused up to the end of the shelf life by replacing the static mixer or resealing cartridge with the sealing cap

Sample applications

Suitable for the fixation of facades, roofs, wood constructions, metal constructions; metal profiles, columns, beams, consoles, railings, sanitary devices, cable trays, pipings, post-installed rebar connection (reconstruction or reinforcement), etc.

Handling and storage

- Storage: store in a cold and dark place, storage temperature: from -20 °C up to +25 °C
- Shelf life: 12 months for foil tube, 18 months for coaxial cartridge
- Expiry date marked on the cartridges (e.g. 123 SEP16 = September 2016)

Sormat ITH-Wi

Vinylester based winter resin, styrene free

ITH-Wi - VINYLESTER BASED WINTER RESIN STYRENE FREE

Applications and intended use

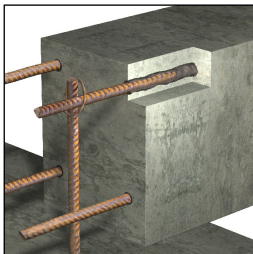
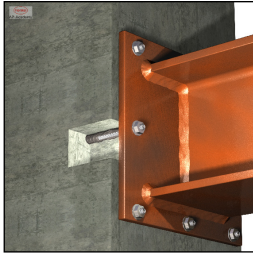

- **Base materials:**
cracked concrete, non-cracked concrete, light-concrete, porous-concrete, solid masonry, hollow brick, natural stone (Attention! natural stone, can discolor; shall be checked in advance); hammer drilled holes, (hollow material shall be drilled without hammer action)
- **Anchor elements:**
Threaded rods (zinc plated or hdg, stainless steel and high corrosion resistant steel), reinforcing bars, female threaded sockets, profiled rods, steel sections with undercuts
- **Temperature range:**
-20 °C up to +20 °C installation temperature
cartridge temperature min. -20 °C (easier extrusion can be achieved with warmer cartridges)
-40 °C to +120 °C base material temperature after full curing

Resin properties

Properties	Test Method	Result
Density		1,65 kg / dm ³
Compressive strength	EN 196 Part 1	80 N / mm ²
Bending strength	EN 196 Part 1	17 N / mm ²
Dynamic modulus of elasticity	EN 196 Part 1	4000 N / mm ²
Mortar water-impermeable	acc. to DIN EN 12390-8	

Curing times

Temperature of base material	Gel-/ working time	Full curing time in dry base material	Full curing time in wet base material
-20 °C to -16 °C	75 min	24 h	48 h
-15 °C to -11 °C	55 min	16 h	32 h
-10 °C to -4 °C	35 min	10 h	20 h
-5 °C to -1 °C	20 min	5 h	10 h
0 °C to +4 °C	10 min	2,5 h	5 h
+5 °C to +9 °C	6 min	80 min	160 min
+10 °C	6 min	60 min	120 min
+15 °C	3 min	45 min	90 min
+20 °C	1,5 min	35 min	70 min
Cartridge temperature -20 °C to +10 °C			

Sormat ITH-Wi

Vinylester based winter resin, styrene free

Installation instructions - concrete

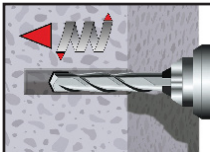
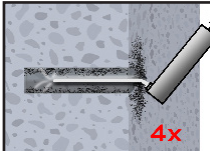
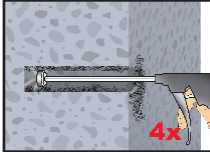
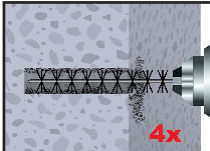
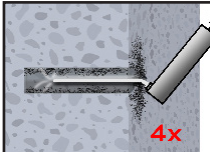
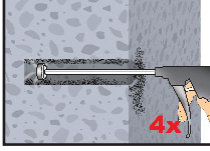
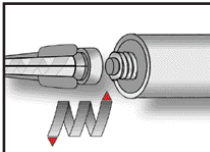
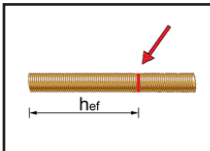
	<p>1. Drill with hammer drill action a hole into the base material to the size and embedment depth required by the selected anchor.</p>
	<p>2a. Standing water must be removed before cleaning. Starting from the bottom or back of the bore hole, blow the hole clean with compressed air or a hand pump a minimum of four times. If the bore hole ground is not reached an extension shall be used. The hand pump can be used for anchor sizes up to bore hole diameter 20 mm. For bore holes larger than 20 mm or deeper than 240 mm, compressed air (min. 6 bar) must be used.</p>
<p>or</p> 	
	<p>2b. Check the right brush diameter and brush the hole with an appropriate sized wire brush of four times. If the bore hole ground is not reached with the brush, a brush extension shall be used.</p>
	<p>2c. Finally blow the hole clean again with compressed air or a hand pump a minimum of four times. If the bore hole ground is not reached an extension shall be used. The hand pump can be used for anchor sizes up to bore hole diameter 20 mm. For bore holes larger then 20 mm or deeper then 240 mm, compressed air (min. 6 bar) must be used.</p>
<p>or</p> 	
	<p>3. Attach a supplied static-mixing nozzle to the cartridge and load the cartridge into the correct dispensing tool (please note that 300 ml cartridge needs to be cut open prior to attaching the static-mixing nozzle). After every working pause longer than the recommended working time as well as for new cartridges, a new static-mixer shall be used.</p>
	<p>4. Prior to inserting the anchor rod into the filled bore hole, the position of the embedment depth shall be marked on the anchor rods.</p>

ITH-Wi - VINYLESTER BASED WINTER RESIN STYRENE FREE

Sormat ITH-Wi

Vinylester based winter resin, styrene free

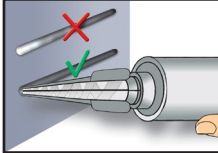
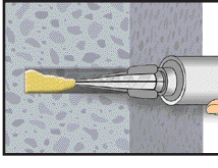
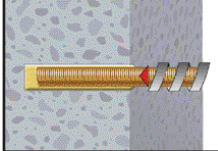
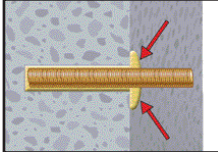
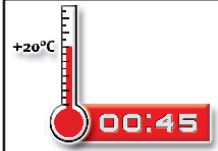
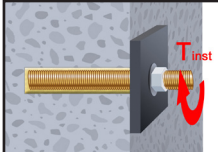
	<p>5. Prior to dispensing into the anchor hole, squeeze out separately a minimum of three full strokes (≥ 10 cm) and discard non-uniformly mixed adhesive components until the mortar shows a consistent grey color.</p>
	<p>6. Starting from the bottom resp. back of the cleaned anchor hole fill the hole up to approximately 2/3 with adhesive. Slowly withdraw of the static mixing nozzle as the hole is filled avoids creating air pockets. For embedments larger than 190 mm an extension nozzle shall be used. For overhead and horizontal installation in bore holes bigger than 20 mm resp. deeper than 240 mm a piston plug shall be used. Observe the gel-/ working times given.</p>
	<p>7. Push the threaded rod or reinforcement bar into the anchor hole while turning slightly to ensure positive distribution of the adhesive until the embedment depth is reached. The anchor should be free of dirt, grease, oil or other foreign material.</p>
	<p>8. Be sure that the anchor is fully seated at the bottom of the hole and that excess mortar is visible at the top of the hole. If these requirements are not met, the installation has to be repeated.</p>
	<p>9. Allow the adhesive to cure to the specified time prior to applying any load or torque. Do not move or load the anchor until it is fully cured.</p>
	<p>10. After full curing, the fixture can be installed with the max. torque by using a calibrated torque wrench.</p>

Sormat ITH-Wi

Vinylester based winter resin, styrene free

Cleaning of the drill hole - concrete



Brush



Blower



Piston plug

Threaded rod (mm)	Rebar (mm)	Bore hole-Ø (mm)	Brush-Ø d_b (mm)	Min. brush-Ø $d_{b,min}$ (mm)	Piston plug (Nr.)
M 8		10,0	12,0	10,5	not necessary
M 10	8,0	12,0	14,0	12,5	
M 12	10,0	14,0	16,0	14,5	
	12,0	16,0	18,0	16,5	
M 16	14,0	18,0	20,0	18,5	
	16,0	20,0	22,0	20,5	
M 20	20,0	24,0	26,0	24,5	# 24
M 24		28,0	30,0	28,5	# 28
M 27	25,0	32,0	34,0	32,5	# 32
M 30	28,0	35,0	37,0	35,5	# 35
	32,0	40,0	41,5	40,5	# 38

ITH-Wi - VINYLESTER BASED WINTER RESIN STYRENE FREE

Sormat ITH-Wi

Vinylester based winter resin, styrene free

Installation parameters - concrete

Anchor size (threaded rod)				M8	M10	M12	M16	M20	M24	M27	M30
Edge distance		$C_{cr,N}$	[mm]	92	126	152	188	253	291	312	329
Min. edge distance	5,0 x d	C_{min}	[mm]	40	50	60	80	100	120	135	150
Spacing		$S_{cr,N}$	[mm]	184	252	304	376	506	582	624	658
Min. spacing	5,0 x d	S_{min}	[mm]	40	50	60	80	100	120	135	150
Embedment depth, min.		$h_{ef,min}$	[mm]	60	60	70	80	90	96	108	120
Embedment depth, standard		h_{ef}	[mm]	80	90	110	125	170	210	250	280
Embedment depth, max		$h_{ef,max}$	[mm]	160	200	240	320	400	480	540	600
Min. base material thickness		h_{min}	[mm]	$h_{ef} + 30 \text{ mm}$ ($\geq 100 \text{ mm}$)			$h_{ef} + 2d_0$				
Anchor diameter		d	[mm]	8	10	12	16	20	24	27	30
Drill diameter		d_0	[mm]	10	12	14	18	24	28	32	35
Installation torque		T_{inst}	[Nm]	10	20	40	80	120	160	180	200

Anchor size (rebar)				Ø 8	Ø 10	Ø 12	Ø 14	Ø 16	Ø 20	Ø 25	Ø 28	Ø 32
Edge distance		$C_{cr,N}$	[mm]	92	126	152	173	188	253	303	323	341
Min. edge distance	5,0 x d	C_{min}	[mm]	40	50	60	70	80	100	125	140	160
Spacing		$S_{cr,N}$	[mm]	184	252	304	346	376	506	606	646	682
Min. spacing	5,0 x d	S_{min}	[mm]	40	50	60	70	80	100	125	140	160
Embedment depth, min.		$h_{ef,min}$	[mm]	60	60	70	75	80	90	100	112	128
Embedment depth, standard		h_{ef}	[mm]	80	90	110	115	125	170	210	250	280
Embedment depth, max		$h_{ef,max}$	[mm]	160	200	240	280	320	400	480	540	600
Min. base material thickness		h_{min}	[mm]	$h_{ef} + 30 \text{ mm}$ ($\geq 100 \text{ mm}$)			$h_{ef} + 2d_0$					
Anchor diameter		d	[mm]	8	10	12	14	16	20	25	28	32
Drill diameter		d_0	[mm]	12	14	16	18	20	24	32	35	40

Sormat ITH-Wi

Vinylester based winter resin, styrene free

Capacities - concrete (threaded rod) ¹⁾

TENSION LOADS - Design method acc. to Technical Report TR 029, characteristic values for tension loading

Anchor size (threaded rod)			M8	M10	M12	M16	M20	M24	M27	M30	
Steel failure											
Characteristic tension resistance, steel, zinc plated or hdg, property class 4.6	$N_{Rk,s}$	[kN]	15	23	34	63	98	141	184	224	
Partial safety factor	$Y_{Ms,N}$		2,0								
Characteristic tension resistance, steel, zinc plated or hdg, property class 5.8	$N_{Rk,s}$	[kN]	18	29	42	78	122	176	230	280	
Characteristic tension resistance, steel, zinc plated or hdg, property class 8.8	$N_{Rk,s}$	[kN]	29	46	67	125	196	282	368	449	
Partial safety factor	$Y_{Ms,N}$		1,50								
Characteristic tension resistance, stainless steel A4 and HCR	$N_{Rk,s}$	[kN]	26	41	59	110	171	247	230	281	
Partial safety factor	$Y_{Ms,N}$		1,87						2,86		
Pullout and concrete cone failure ²⁾											
Characteristic bond resistance in concrete C20/25											
40 °C/24 °C ³⁾	non-cracked concrete	$N_{Rk,p} = N_{Rk,c}^0$	[kN]	20,1	33,9	49,7	75,4	128	174	212	237
	cracked concrete			9,0	15,6	22,8	34,6	58,7	87,1	138	171
80 °C/50 °C ³⁾	non-cracked concrete			15,1	25,4	37,3	56,5	96,1	135	159	171
	cracked concrete			6,0	11,3	16,6	25,1	42,7	63,3	95,4	119
120 °C/72 °C ³⁾	non-cracked concrete			11,1	18,4	27,0	40,8	69,4	103	117	132
	cracked concrete			5,0	8,5	12,4	18,8	32,0	47,5	74,2	92,4
Partial safety factor	$Y_{Mp} = Y_{Mc}$		1,5	1,8							
Embedment depth ^{*)}	h_{ef}	[mm]	80	90	110	125	170	210	250	280	
Edge distance	$c_{cr,N}$	[mm]	92	126	152	188	253	291	312	329	
Spacing	$s_{cr,N}$	[mm]	$2 \times c_{cr,N}$								
Increasing factors for concrete y_c			$(f_{ck}^{0,11})/1,42$								
Splitting failure											
Edge distance	$c_{cr,sp}$	[mm]	$1,0 \times h_{ef} \leq 2 \times h_{ef} (2,5 - h/h_{ef}) \leq 2,4 \times h_{ef}$								
Spacing	$s_{cr,sp}$	[mm]	$2 \times c_{cr,sp}$								
Partial safety factor	Y_{Msp}		1,5	1,8							

The data in this table are intended to use together with the design provisions of TR 029.

* For easier calculation e.g. for variable embedment depths, use Sormat Trustfix calculation software.

¹⁾ For more details, as well as values in water filled concrete see ETA-13/0774.

²⁾ Shall be determined acc. to this table or to TR 029. The smaller value is decisive.

³⁾ Short term temperature / long term temperature. Long term concrete temperatures are roughly constant over significant periods of time. Short term elevated temperatures are those that occur over brief intervals, e.g. as a result of diurnal cycling.

Sormat ITH-Wi

Vinylester based winter resin, styrene free

Capacities - concrete (threaded rod)¹⁾

SHEAR LOADS - Design method acc. to Technical Report TR 029, characteristic values for shear loading

Anchor size (threaded rod)			M8	M10	M12	M16	M20	M24	M27	M30	
<u>Steel failure without lever arm</u>											
Characteristic shear resistance, steel, zinc plated or hdg property class 4.6	$V_{Rk,s}$	[kN]	7	12	17	31	49	71	92	112	
Partial safety factor	$\gamma_{Ms,V}$		1,67								
Characteristic shear resistance, steel, zinc plated or hdg, property class 5.8	$V_{Rk,s}$	[kN]	9	15	21	39	61	88	115	140	
Characteristic shear resistance, steel, zinc plated or hdg, property class 8.8	$V_{Rk,s}$	[kN]	15	23	34	63	98	141	184	224	
Partial safety factor	$\gamma_{Ms,V}$		1,25								
Characteristic shear resistance, stainless steel A4 and HCR	$V_{Rk,s}$	[kN]	13	20	30	55	86	124	115	140	
Partial safety factor	$\gamma_{Ms,V}$		1,56						2,38		
<u>Steel failure with lever arm</u>											
Characteristic bending moment, steel, zinc plated or hdg, property class 4.6	$M^0_{Rk,s}$	[kN]	15	30	52	133	260	449	666	900	
Partial safety factor	$\gamma_{Ms,V}$		1,67								
Characteristic bending moment, steel, zinc plated or hdg, property class 5.8	$M^0_{Rk,s}$	[Nm]	19	37	65	166	324	560	833	1123	
Characteristic bending moment, steel, zinc plated or hdg, property class 8.8	$M^0_{Rk,s}$	[kN]	30	60	105	266	519	896	1333	1797	
Partial safety factor	$\gamma_{Ms,V}$		1,25								
Characteristic bending moment, stainless steel A4 and HCR	$M^0_{Rk,s}$	[kN]	26	52	92	232	454	784	832	1125	
Partial safety factor	$\gamma_{Ms,V}$		1,56						2,38		
<u>Concrete pry-out failure</u>											
Factor k in equation (5.7) of TR 029			2,0								
Partial safety factor	γ_{Mcp} ¹⁾		1,5								
<u>Concrete edge failure</u>											
Partial safety factor	γ_{Mc}		1,5								

The data in this table is intended to be used together with the design provisions of TR 029.

For easier calculation e.g. for variable embedment depths, use Sormat Trustfix calculation software.

¹⁾ For more details, as well as values in water filled concrete see ETA-13/0774.

Sormat ITH-Wi

Vinylester based winter resin, styrene free

Capacities - concrete (rebar)¹⁾

TENSION LOADS - Design method acc. to Technical Report TR 029, characteristic values for tension loading

Anchor size (rebar)			Ø 8	Ø 10	Ø 12	Ø 14	Ø 16	Ø 20	Ø 25	Ø 28	Ø 32	
<u>Steel failure</u>												
Characteristic tension resistance, BSt 500 S acc. to DIN 488-2:1986 or E DIN 488-2:2006 ²⁾		$N_{Rk,s}$	[kN]	28	43	62	85	111	173	270	339	442
Partial safety factor		$\gamma_{Ms,N}$		1,87						2,86		
<u>Pullout and concrete cone failure³⁾</u>												
Characteristic bond resistance in concrete C20/25												
40 °C/24 °C ³⁾	non-cracked concrete	$N_{Rk,p} = N_{Rk,c}^0$	[kN]	20,1	33,9	49,8	60,7	75,4	128	181	220	239
	cracked concrete			9,0	15,6	22,8	27,8	34,6	58,7	90,7	143	183
80 °C/50 °C ³⁾	non-cracked concrete			15,1	25,4	37,3	45,5	56,5	96,1	132	154	169
	cracked concrete			6,0	11,3	16,6	20,2	25,1	42,7	66,0	99,0	127
120 °C/72 °C ³⁾	non-cracked concrete			11,1	18,4	27,0	32,9	40,8	69,4	99,0	110	127
	cracked concrete			5,0	8,5	12,4	15,2	18,8	32,0	49,5	77,0	98,0
Partial safety factor		$\gamma_{Mp} = \gamma_{Mc}$	1,5	1,8								
Embedment depth		h_{ef}	[mm]	80	90	110	115	125	170	210	250	280
Edge distance		$c_{cr,N}$	[mm]	92	126	152	173	188	253	303	323	341
Spacing		$s_{cr,N}$	[mm]	$2 \times c_{cr,N}$								
Increasing factors for concrete γ_c				$(f_{ck}^{0,11})/1,42$								
<u>Splitting failure</u>												
Edge distance		$c_{cr,sp}$	[mm]	$1,0 \times h_{ef} \leq 2 \times h_{ef} \quad (2,5 - h/h_{ef}) \leq 2,4 \times h_{ef}$								
Spacing		$s_{cr,sp}$	[mm]	$2 \times c_{cr,sp}$								
Partial safety factor		γ_{Msp}	1,5	1,8								

The data in this table are intended to use together with the design provisions of TR 029.

¹⁾ For more details, as well as values in water filled concrete see ETA-13/0774.

²⁾ For reinforcing bars which do not comply with DIN 488: the characteristic resistance $N_{Rk,s}$ shall be determined acc. to Technical Report TR 029, equation (5.1).

³⁾ Shall be determined acc. to this table or to TR 029. The smaller value is decisive.

⁴⁾ Short term temperature / long term temperature . Long term concrete temperatures are roughly constant over significant periods of time. Short term elevated temperatures are those that occur over brief intervals, e.g. as a result of diurnal cycling.

Sormat ITH-Wi

Vinylester based winter resin, styrene free

Capacities - concrete (rebar)¹⁾

SHEAR LOADS - Design method acc. to Technical Report TR 029, characteristic values for shear loading

Anchor size (rebar)		Ø 8	Ø 10	Ø 12	Ø 14	Ø 16	Ø 20	Ø 25	Ø 28	Ø 32	
<u>Steel failure without lever arm</u>											
Characteristic shear resistance, BSt 500 S acc. to DIN 488-2:1986 or DIN 488-2:2006 ²⁾	$V_{Rk,s}$	[kN]	14	22	31	42	55	86	135	169	221
Partial safety factor	$\gamma_{Ms,V}$		1,5								
<u>Steel failure with lever arm</u>											
Characteristic bending moment, BSt 500 S acc. to DIN 488-2:1986 or DIN 488-2:2006 ³⁾	$M^0_{Rk,s}$	[kN]	33	65	112	178	265	518	1012	1422	2123
Partial safety factor	$\gamma_{Ms,V}$		1,5								
<u>Concrete pry-out failure</u>											
Factor k in equation (5.7) of TR 029			2,0								
Partial safety factor	γ_{Mcp}		1,5								
<u>Concrete edge failure</u>											
Partial safety factor	γ_{Mc}		1,5								

The data in this table is intended to be used together with the design provisions of TR 029.

¹⁾ For more details, as well as values in water filled concrete see ETA-13/0774.

²⁾ For reinforcing bars which do not comply with DIN 488: the characteristic resistance $V_{Rk,s}$ shall be determined acc. to Technical Report TR 029, equation (5.5).

³⁾ For reinforcing bars which do not comply with DIN 488: the characteristic bending moment $M^0_{Rk,s}$ shall be determined acc. to Technical Report TR 029, equation (5.5b).

Sormat ITH-Wi

Vinylester based winter resin, styrene free

Capacities - concrete (Seismic C1)

Design under seismic action acc. to TR 045

The decision of the selection of the seismic performance category is in the responsibility of each individual Member State. Furthermore, the values of $a_g \cdot S$ assigned to the seismicity levels may be different in the National Annexes to EN 1998-1:2004 (EC8) compared to the values given in the following table. The recommended category C1 and C2 given in the following table are given in case that no National requirements are defined.

Recommended seismic performance categories

Seismicity level ^{a)}		Importance Class acc. to EN 1998-1:2004, 4.2.5			
	$a_g \cdot S$ ^{c)}	I	II	III	IV
Very low ^{b)}	$a_g \cdot S \leq 0,05 \text{ g}$	No additional requirement			
low ^{b)}	$0,05 \text{ g} < a_g \cdot S \leq 0,1 \text{ g}$	C1	C1 ^{d)} or C2 ^{e)}		C2
> low ^{b)}	$a_g \cdot S > 0,1 \text{ g}$	C1	C2		

^{a)} The values defining the seismicity levels may be found in the National Annex of EN 1998-1.

^{b)} Definition according to EN 1998-1:2004, 3.2.1.

^{c)} a_g = Design ground acceleration on Type A ground (EN 1998-1: 2004, 3.2.1),
 S = soil factor (see e.g. EN 1998-1: 2004, 3.2.2).

^{d)} C1 attachments of non-structural elements

^{e)} C2 for connections between structural elements of primary and/or secondary seismic members

Calculation of characteristic seismic resistance $R_{k,seis}$

Tension load: $R_{k,seis} = \alpha_{gap} \cdot \alpha_{seis} \cdot \alpha_{N,seis} \cdot R_k^0$

with $R_k^0 = N_{Rk,s'} \cdot N_{Rk,p'} \cdot N_{Rk,c'} \cdot N_{Rk,sp}$ (from design in cracked concrete)
 $\alpha_{N,seis} = 1,0$ for $N_{Rk,c'}$ $N_{Rk,sp}$
 $\alpha_{N,seis}$ = for $N_{Rk,s'}$ $N_{Rk,p}$ see following tables
 α_{gap} = see following tables
 α_{seis} = see following tables

Shear load: $R_{k,seis} = \alpha_{gap} \cdot \alpha_{seis} \cdot \alpha_{V,seis} \cdot R_k^0$

with $R_k^0 = V_{Rk,s'} \cdot V_{Rk,c'} \cdot V_{Rk,cp}$ (from design in cracked concrete)
 $\alpha_{V,seis} = 1,0$ for $V_{Rk,c'}$ $V_{Rk,cp}$
 $\alpha_{V,seis}$ = for $V_{Rk,s}$ see following tables
 α_{gap} = see following tables
 α_{seis} = see following tables

Sormat ITH-Wi

Vinylester based winter resin, styrene free

Capacities - concrete (Seismic C1)

Reduction factors $\alpha_{N,seis}$, $\alpha_{V,seis}$, α_{gap} and α_{seis}

Anchor size threaded rod ¹⁾			M8	M10	M12	M16	M20	M24	M27	M30	M33	M36	M39	
Tension load														
Steel failure ($N_{Rk,s}$)	$\alpha_{N,seis}$	[-]	1,0											
Combined pull-out and concrete failure ($N_{Rk,p}$)	$\alpha_{N,seis}$	[-]	0,68					0,69						
Shear load														
Steel failure without lever arm ($V_{Rk,s}$)	$\alpha_{V,seis}$	[-]	0,70											

Anchor size rebar ¹⁾			Ø 8	Ø 10	Ø 12	Ø 14	Ø 16	Ø 20	Ø 25	Ø 28	Ø 32	Ø 36	Ø 40	
Tension load														
Steel failure ($N_{Rk,s}$)	$\alpha_{N,seis}$	[-]	1,0											
Combined pull-out and concrete failure ($N_{Rk,p}$)	$\alpha_{N,seis}$	[-]	0,68					0,69						
Shear load														
Steel failure without lever arm ($V_{Rk,s}$)	$\alpha_{V,seis}$	[-]	0,70											

Loading	Failure modes	α_{gap}	α_{seis} – single fastener	α_{seis} – fastener group
Tension	Steel failure	1,0	1,0	1,0
	Pull-out failure	1,0	1,0	0,85
	Combined pull-out and concrete failure	1,0	1,0	0,85
	Concrete cone failure	1,0	0,85	0,75
	Splitting failure	1,0	1,0	0,85
Shear	Steel failure without lever arm	0,5 ¹⁾	1,0	0,85
	Steel failure with lever arm	NPD ²⁾	NPD ²⁾	NPD ²⁾
	Concrete edge failure	0,5 ¹⁾	1,0	0,85
	Concrete pry-out failure	0,5 ¹⁾	0,85	0,75

¹⁾ The limitation for size of the clearance hole is given in TR 029 Table 4.1,

$\alpha_{gap} = 1,0$ in case of no clearance between fastener and fixture

²⁾ NPD = No Performance Determined

Sormat ITH-Wi

Vinylester based winter resin, styrene free

Recommended loads - concrete

The recommended loads are only valid for single anchor for a roughly design, if the following conditions are valid:

$$c \geq c_{cr,N} \quad s \geq s_{cr,N} \quad h \geq 2 \times h_{ef}$$

If the conditions are not fulfilled the loads must be calculated acc. to EOTA Technical Report TR 029.

The safety factors are already included in the recommended loads.

Anchor size (steel quality 5.8) ¹⁾				M8	M10	M12	M16	M20	M24	M27	M30	
Recommended tension load	40 °C/24 °C ³⁾	non-cracked concrete	$N_{Rec,stat}$	[kN]	8,6	13,5	19,7	28,0	44,4	61,0	79,2	93,9
		cracked concrete	$N_{Rec,stat}$	[kN]	4,3	6,2	9,1	13,7	23,3	34,6	54,7	66,9
			$N_{Rec,seis}$	[kN]	2,9	4,2	6,2	9,3	15,9	23,8	37,7	46,2
	80 °C/50 °C ³⁾	non-cracked concrete	$N_{Rec,stat}$	[kN]	7,2	10,1	14,8	22,4	38,1	53,4	63,1	68,1
		cracked concrete	$N_{Rec,stat}$	[kN]	2,9	4,5	6,6	10,0	17,0	25,1	37,9	47,1
			$N_{Rec,seis}$	[kN]	2,0	3,1	4,5	6,8	11,5	17,3	26,1	32,5
	120 °C/72 °C ³⁾	non-cracked concrete	$N_{Rec,stat}$	[kN]	5,3	7,3	10,7	16,2	27,6	40,8	46,3	52,4
		cracked concrete	$N_{Rec,stat}$	[kN]	2,4	3,4	4,9	7,5	12,7	18,8	29,5	36,7
			$N_{Rec,seis}$	[kN]	1,6	2,3	3,4	5,1	8,6	13,0	20,3	25,3
Recommended shear load without lever arm ²⁾	non-cracked concrete	$V_{Rec,stat}$	[kN]	5,1	8,6	12,0	22,3	34,9	50,3	59,3	65,5	
		$V_{Rec,stat}$	[kN]	3,3	5,6	7,5	12,3	18,0	23,7	31,9	37,8	
	cracked concrete	$V_{Rec,seis}$	[kN]	1,7	2,8	3,8	6,1	9,0	11,9	16,0	18,9	
Embedment depth			h_{ef}	[mm]	80	90	110	125	170	210	250	280
Edge distance			$c_{cr,N}$	[mm]	92	126	152	188	253	291	312	329
Spacing			$s_{cr,N}$	[mm]	$2 \times c_{cr,N}$							

¹⁾ Sizes M8 and M10 are covered by ETA only in non-cracked concrete.

²⁾ Shear load with lever arm acc. TR 029.

³⁾ Short term temperature / long term temperature

$N_{Rec,stat}$ / $V_{Rec,stat}$ = recommended load under static and quasi-static action

$N_{Rec,seis}$ / $V_{Rec,seis}$ = recommended load under seismic action

Sormat ITH-Wi

Vinylester based winter resin, styrene free

Recommended loads - concrete

The recommended loads are only valid for single anchor for a roughly design, if the following conditions are valid:

$$c \geq c_{cr,N} \quad s \geq s_{cr,N} \quad h \geq 2 \times h_{ef}$$

If the conditions are not fulfilled the loads must be calculated acc. to EOTA Technical Report TR 029.

The safety factors are already included in the recommended loads.

Rebar size (BSt 500) ¹⁾				Ø 8	Ø 10	Ø 12	Ø 14	Ø 16	Ø 20	Ø 25	Ø 28	Ø 32
Recommended tension load	40°C/24°C ³⁾	non-cracked concrete	$N_{Rec,stat}$	9,6	13,5	19,7	24,1	28,0	44,4	61,0	79,2	93,9
		cracked concrete	$N_{Rec,stat}$	4,3	6,2	9,1	11,0	13,7	23,3	36,0	56,5	66,9
			$N_{Rec,seis}$	2,9	4,2	6,2	7,5	9,3	15,9	24,8	39,0	46,2
	80°C/50°C ³⁾	non-cracked concrete	$N_{Rec,stat}$	7,2	10,1	14,8	18,1	22,4	38,1	52,4	61,1	67,0
		cracked concrete	$N_{Rec,stat}$	2,9	4,5	6,6	8,0	10,0	17,0	26,2	39,3	50,3
			$N_{Rec,seis}$	2,0	3,1	4,5	5,5	6,8	11,5	18,1	27,1	34,7
	120°C/72°C ³⁾	non-cracked concrete	$N_{Rec,stat}$	5,3	7,3	10,7	13,0	16,2	27,6	39,3	43,6	50,3
		cracked concrete	$N_{Rec,stat}$	2,4	3,4	4,9	6,0	7,5	12,7	19,6	30,5	39,1
			$N_{Rec,seis}$	1,6	2,3	3,4	4,1	5,1	8,6	13,5	21,1	27,0
Recommended shear load without lever arm ²⁾	non-cracked concrete	$V_{Rec,stat}$	6,7	10,5	14,8	20,0	26,2	41,0	56,6	62,5	69,3	
	cracked concrete	$V_{Rec,stat}$	3,3	5,6	7,5	9,9	12,3	18,0	25,7	33,6	41,4	
		$V_{Rec,seis}$	1,7	2,8	3,8	5,0	6,1	9,0	12,8	16,8	20,7	
Embedment depth	h_{ef}	[mm]	80	90	110	115	125	170	210	250	280	
Edge distance	$c_{cr,N}$	[mm]	92	126	152	173	188	253	303	323	341	
Spacing	$s_{cr,N}$	[mm]	$2 \times c_{cr,N}$									

¹⁾ Sizes 8 and 10 are covered by ETA only in non-cracked concrete.

²⁾ Shear load with lever arm acc. TR 029.

³⁾ Short term temperature / long term temperature

$N_{Rec,stat}$, $V_{Rec,stat}$ = recommended load under static and quasi-static action

$N_{Rec,seis}$, $V_{Rec,seis}$ = recommended load under seismic action

Sormat ITH-Wi

Vinylester based winter resin, styrene free

Installation instructions - hollow bricks

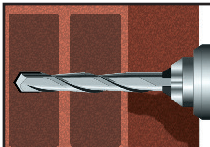
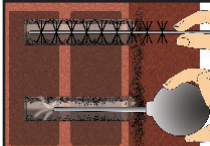
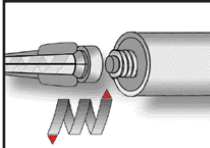
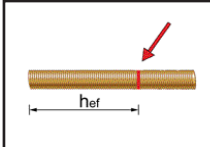
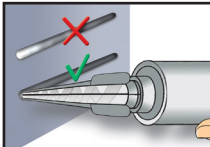
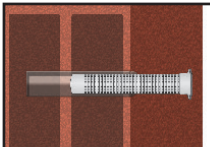
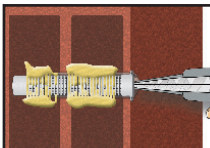
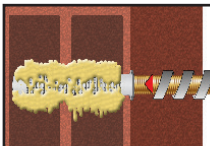
	<p>1. Drill without hammer drill action a hole into the base material to the size and embedment depth required by the selected anchor.</p>
	<p>2. In case of a water filled bore hole, the water has to be removed from the hole (e.g. by compressed air or vacuum cleaner). Starting from the bottom or back of the hole, blow the hole clean with a hand pump a minimum of two times. Then brush the hole with a brush a minimum of two times. Finally clean the hole again with a hand pump a minimum of two times.</p>
	<p>3. Attach a supplied static-mixing nozzle to the cartridge and load the cartridge into the correct dispensing tool (please note that 300 ml cartridge needs to be cut open prior to attaching the static-mixing nozzle). After every working pause longer than the recommended working time as well as for new cartridges, a new static-mixer shall be used.</p>
	<p>4. Prior to inserting the anchor rod into the filled bore hole, the position of the embedment depth shall be marked on the anchor rods.</p>
	<p>5. Prior to dispensing the mortar into the bore hole, squeeze out separately a minimum of three full strokes (≥ 10 cm) and discard non-uniformly mixed adhesive components until the mortar shows a consistent grey colour.</p>
	<p>6. Insert the perforated plastic sleeve into the bore hole. Make sure that the sleeve fits well into the hole. Only use sleeves that have the right length.</p>
	<p>7. Starting from the back fill the sleeve completely with adhesive. Observe the gel-/working times.</p>
	<p>8. Push the threaded rod or reinforcement bar into the sleeve while turning it slightly to ensure a distribution of the adhesive until the back of the sleeve is reached. The anchor rod should be free of dirt, grease, oil or other foreign material.</p>

ITH-Wi - VINYLESTER BASED WINTER RESIN STYRENE FREE

Sormat ITH-Wi

Vinylester based winter resin, styrene free

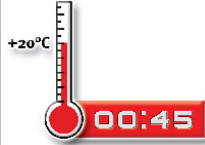
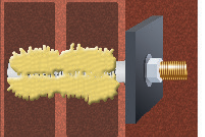
	<p>9. Allow the adhesive to cure to the specified time prior to applying any load or torque. Do not move or load the anchor until it is fully cured.</p>
	<p>10. After full curing, the fixture can be installed with the max. torque by using a calibrated torque wrench.</p>

Cleaning - masonry



• Brush

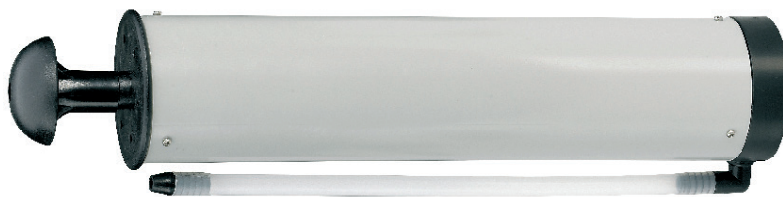

• Blower

Sormat ITH-Wi

Vinylester based winter resin, styrene free



Capacities - masonry

with standard perforated plastic sleeve IOV

Stone	Strength class	Standard sleeves		IOV 12x50	IOV 16x85	IOV 16x135	IOV 20x85
		Anchor size		M6 / M8	M8 / M10		M12 / M16
Hollow brick	Hlz 4	F _{rec}	[kN]	0,3	0,3	0,3	0,3
	Hlz 6			0,4	0,4	0,4	0,4
	Hlz 12			0,7	0,8	0,8	0,8
Sand -lime hollow brick	KSL 4	F _{rec}	[kN]	0,3	0,3	0,3	0,3
	KSL 6			0,4	0,4	0,4	0,4
	KSL 12			0,7	0,8	0,8	0,8
Sand -lime solid brick ¹⁾	KS 12	F _{rec}	[kN]	1,0	1,7	1,7	1,7
Solid brick ¹⁾	Mz 12	F _{rec}	[kN]	1,0	1,7	1,7	1,7
Light concrete hollow brick	Hbl 2	F _{rec}	[kN]	0,3	0,3	0,3	0,3
	Hbl 4			0,5	0,6	0,6	0,6
Concrete hollow brick	Hbn 4	F _{rec}	[kN]	0,5	0,6	0,6	0,6

Installation parameters							
Spacing plug group		S _{cr,N Group}	[mm]	Hlz, KSL, MZ, KS = 100 Hbl, Hbn = 200			
Min. spacing plug group ²⁾		S _{min Group}	[mm]	Hlz, KSL, MZ, KS = 50 Hbl, Hbn = 200			
Spacing between single plugs		S _{cr,N Single}	[mm]	250			
Edge distance		C _{cr,N}	[mm]	250			
Min. edge distance ⁴⁾		c _{min}	[mm]	250			
with sleeve	Embedment depth of rod	h _{ef}	[mm]	50	85	135	85
	Drilling depth	h _o	[mm]	55	90	140	90
	Min. base material thickness	h _{min}	[mm]	110	110	160	110
	Drill diameter	d _o	[mm]	12	16		20
without sleeve	Embedment depth of rod	h _{ef}	[mm]	60 / 80	80 / 90		90
	Drilling depth	h _o	[mm]	65 / 85	85 / 95		95
	Min. base material thickness	h _{min}	[mm]	85 / 100	100 / 110		110
	Drill diameter	d _o	[mm]	8 / 10	10 / 12		14 / 18
Hole diameter in fixture		d _f	[mm]	7 / 9	9 / 11		13 / 17
Installation torque		T _{inst}	[Nm]	4			

¹⁾ Anchoring in masonry of solid lime-sand bricks (KS) and masonry bricks (Mz) does not require perforated sleeve.

²⁾ It is permissible to go below the spacing to the minimum value for anchor pairs and groups of four, if the permissible loads are reduced. The maximum loads must not be exceeded.

⁴⁾ Applies to masonry with top load or proof of tilt. Does not apply to shear loads directed towards a free edge.

Sormat ITH-Wi

Vinylester based winter resin, styrene free



Parameters - masonry

with standard perforated plastic sleeve IOV

Reduced permissible loads with reduced spacing per anchor in anchor groups

$$s_{cr,N \text{ Group}} \geq s > s_{\min}$$

Anchor pairs:

$$\text{red } F = \chi s \cdot F_{\text{rec}}$$

$$\chi s = \frac{1}{2} \left(1 + \frac{s}{s_{cr,N \text{ Group}}} \right) \leq 1,0$$

Groups of four:

$$\text{red } F = \chi s_1 \cdot \chi s_2 \cdot F_{\text{rec}}$$

$$\chi s_{1,2} = \frac{1}{2} \left(1 + \frac{s_{1,2}}{s_{cr,N \text{ Group}}} \right) \leq 1,0$$

F_{rec} = permissible load per anchor

red F = reduced load per anchor

$s_{cr,N \text{ Group}}$ = spacing

s = reduced spacing

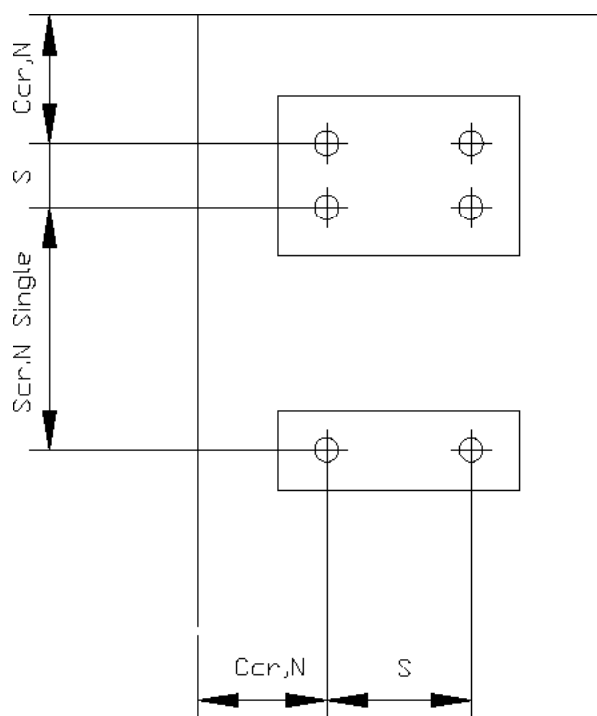

Permissible load in [kN] for each single brick

Brick format		< 4 DF	from 4 to 10 DF	≥ 10 DF
Without top load	max F [kN]	1,0	1,4	2,0
With top load	max F [kN]	1,4	1,7	2,5

DF brick type	DF brick dimensions in mm		
	Length	Width	Height
DF	240	115	52
2 DF	240	115	113
3 DF	240	175	113
5 DF	300	240	113
6 DF	365	240	113
10 DF	300	240	238
12 DF	365	240	238

Sormat ITH-Wi

Vinylester based winter resin, styrene free

Chemical resistance

Chemical Agent	Concentration	Resistant	Not Resistant
Accumulator acid		•	
Acetic acid	40		•
Acetic acid	10	•	
Acetone	10		•
Ammonia, aqueous solution	5	•	
Aniline	100		•
Beer		•	
Benzene (kp 100-140°F)	100	•	
Benzol	100		•
Boric Acid, aqueous solution		•	
Calcium carbonate, suspended in water	all	•	
Calcium chloride, suspended in water		•	
Calcium hydroxide, suspended in water		•	
Carbon tetrachloride	100	•	
Caustic soda solution	10	•	
Citric acid	all	•	
Chlorine water, swimming pool	all	•	
Diesel oil	100	•	
Ethyl alcohol, aqueous solution	50		•
Formic acid	100		•
Formaldehyde, aqueous solution	30	•	
Freon		•	
Fuel Oil		•	
Gasoline (premium grade)	100	•	
Glycol (Ethylene glycol)		•	
Hydraulic fluid	conc.	•	
Hydrochloric acid (Muriatic Acid)	conc.		•
Hydrogen peroxide	30		•
Isopropyl alcohol	100		•
Lactic acid	all	•	
Linseed oil	100	•	
Lubricating oil	100	•	
Magnesium chloride, aqueous solution	all	•	
Methanol	100		•
Motor oil (SAE 20 W-50)	100	•	
Nitric acid	10		•
Oleic acid	100	•	
Perchloroethylene	100	•	
Petroleum	100	•	
Phenol, aqueous solution	8		•
Phosphoric acid	85	•	
Potash lye (Potassium hydroxide)	10	•	
Potassium carbonate, aqueous solution	all	•	
Potassium chlorite, aqueous solution	all	•	
Potassium nitrate, aqueous solution	all	•	
Sea water, salty	all	•	
Sodium carbonate	all	•	
Sodium Chloride, aqueous solution	all	•	
Sodium phosphate, aqueous solution	all	•	
Sodium silicate	all	•	
Standard Benzene	100	•	
Sulfuric acid	10	•	
Sulfuric acid	70		•
Tartaric acid	all	•	
Tetrachloroethylene	100	•	
Toluene			•
Trichloroethylene	100		•
Turpentine	100	•	

Results shown in the table are applicable to brief periods of chemical contact with full cured adhesive (e.g. temporary contact with adhesive during a spill).